



# 2021 Annual Report

**RM of Stanley Public Water System**

**(Red River Regional)**

**System Code: 218.25**

**Reinfeld, Schanzenfeld, Blumstein**



**Name of the public water system:  
RM of Stanley Public Water System**

**Name of the legal owner:  
Rural Municipality of Stanley**

**Water Source:  
Red River Regional Public Water System- Pembina Valley Water CO-OP**

**Emergency Contact Information:**

**Call the RM of Stanley Office: 204-325-4101**

**In the event of an emergency outside of regular business hours you will be transferred to an on-call operator.**

**Email: [info@rmofstanley.ca](mailto:info@rmofstanley.ca)**

**Contact Persons:**

<b>Ken Thiessen</b>	<b>– Public Works Supervisor</b>	<b>-204-362-7335</b>
<b>Dave Rempel</b>	<b>– Utilities Manager</b>	<b>-204-362-2361</b>
<b>Dustin Dyck</b>	<b>– Utility Operator</b>	<b>-204-362-8176</b>
<b>Melanie Walker</b>	<b>– Utilities – (Admin)</b>	<b>-204-325-4101</b>

## Introduction:

This RM of Stanley water system has three different local systems amalgamated into one. The Reinfeld, Schanzenfeld, Blumstein and surrounding areas are represented within the same license. The Schanzenfeld and Reinfeld utility systems began receiving treated water from the Pembina Valley Water Co-op in 2002 and continues to receive water from the PVWC. Water is provided to the un-incorporated villages of Schanzenfeld, Chortitz, Friedensruh, Reinfeld and various other rural properties in the general area. The system continues to expand in order to service continued development being experienced in the area. A 300,000L reservoir expansion was completed in the fall of 2010 in both Schanzenfeld and Reinfeld to accommodate the increase in water connections. This brought the total reservoir storage at each location up to 500,000L.

## Description of the Water System:

### **Source**

This RM of Stanley Public Water System purchases water from the Pembina Valley Water Co-op which draws the water from the Red River at the Letellier Treatment facility in Letellier MB. The Pembina Valley Water Co-op is a wholesaler of water which it sells to the RM of Stanley. The treated water is pumped west along PVWC main lines up to the Reinfeld reservoir and then to the Winkler south booster station where it is pumped into the Schanzenfeld reservoir. It is then distributed to the final consumers.

### **Treatment**

The water is treated at the Pembina Valley Water Co-op Treatment Plant in Letellier. A detailed description of their treatment process can be obtained directly from the PVWC at 204-324-1931 or email: [pvwc@mts.net](mailto:pvwc@mts.net).

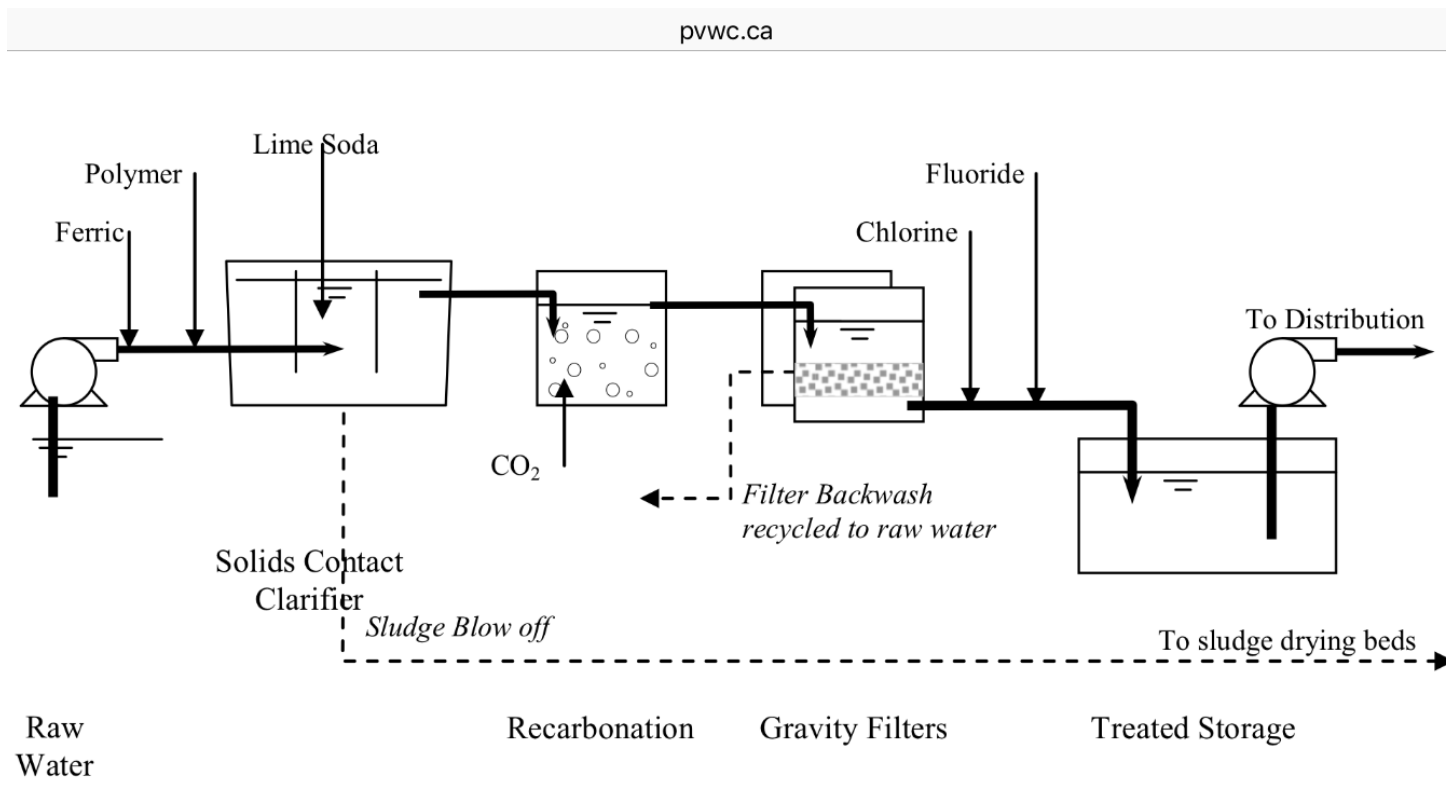

Upon entering Stanley's reservoirs, the treated water is re-chlorinated with sodium hypochlorite to ensure that required disinfection residuals are maintained throughout the system. The treatment systems in the Reinfeld and Schanzenfeld pumphouses were upgraded in 2019 with the purchase of 2 peristaltic chlorine pumps. Treated water is then pumped throughout the distribution system to the final consumer.

### **Distribution**

The distribution system is a network of underground pipes which delivers the water to the end consumers. When the water leaves the reservoirs, it is pumped through various sizes of PVC pipe (2"-6"). Most service line sizes range from ¾" – 1 ½". The total distribution network is approximately 76 kms long. Generators were installed at both Reinfeld and Schanzenfeld pumphouses in 2017 to maintain constant system pressure during power outages. Gate valves are installed throughout the system to be able to isolate sections of line for emergency or maintenance purposes. Curbstops are installed on each service line to be able to shut off residential lines in case of emergencies.

***Customers should take care not to damage valves.***

### **Storage Reservoirs**

In this system we have 1 (one) 200,000 litre reinforced concrete 2-cell reservoir and 1 (one) 300,000 litre reinforced concrete 3-cell reservoir north of Schanzenfeld and 1 (one) 200,000 litre reinforced concrete 2-cell reservoir and 1 (one) 300,000 litre reinforced concrete 3-cell reservoir in Reinfeld. With a capacity of 500,000 litres each, these reservoirs act as a buffer to alleviate peak demands and maintain adequate pressure on the system. At current demands, the reservoirs hold approximately 1 day of storage. The Reinfeld reservoir was cleaned in 2020 with the Schanzenfeld reservoir scheduled for a 2022 cleaning. In addition to our current storage, we are in the planning stages of building a new 4 million liter reservoir close to the BTH hospital (Blumstein System).



### **Number of connections, population served, & types of water users**

At the end of December 2021, the Stanley Water system had 1,092 service connections and billed out an average of 18,287,694 gallons of water per quarter and served an estimated population of 4,368. These systems service 4 Elementary Schools, 7 Churches and a number of large Agricultural & Commercial users while the majority of connections are for residential properties. Stanley also supplies water to the Boundary Trails Hospital. Each connection is equipped with a water meter to measure water volumes for monitoring, administrative, and billing purposes. Water meters are read quarterly by the customer.

### **Classification/Certification**

The Stanley Public Water System (RRR) is classified as a Class Two (2) Distribution System. Classification/certification is regulated under Manitoba Conservation's Water and Wastewater Facility Operators Regulation under *The Environment Act*. Stanley has 2 full-time operators and one part-time. All are certified.

The operators continually participate in educational seminars to keep up their training.

## **Equipment:**

Each pumphouse is equipped with one – 2 horsepower variable speed pump and three - 5 horsepower variable speed pumps with a combined pumping rate of 225 Gallons per minute. All water lines on the system are made of PVC and high-density polyethylene materials. The line pressure along the corridor from Winkler to Morden (Blumstein) is supplied by PVWC.



## **How is the Utility Operator notified in cases of emergencies?**

The water pumphouses uses electronic tele-metering equipment as a means for monitoring operations. This system notifies the utility operator by way of telephone in case of any problems regarding pressures, water levels, power failures, temperatures, and noise levels. This equipment also allows the utility operator to monitor several components of the reservoir operations while off-site through the use of a telephone. The RM of Stanley Utility Operator is notified by telephone in case of any emergency or discrepancy with the system.

In 2020 the Schanzenfeld and Reinfeld systems were upgraded to an electronic monitoring system (PLC) that allows the operators to monitor live pressures, reservoir levels, and flows off-site. This also allows them to diagnose problems and help them trend the operations of the pumphouses.

A Utility Operator is on call 24 hours/day. In case of an emergency call the RM of Stanley office where you will be transferred to an on-call operator.

**Emergency #: 1-204-325-4101**



### Water Quality Standards

There are certain water quality standards that are adhered to for the safety of the public. Below is a list of the health standards that are followed on the Stanley Public Water System. When there is a failure to meet these standards, immediate corrective actions are taken.

Parameter	Quality Standard
Total Coliform	Less than one total coliform bacteria detectable per 100 mL in all distributed water
<i>E. coli</i>	Less than one <i>E. coli</i> bacteria detectable per 100 mL in all distributed water
Chlorine Residual	A free chlorine residual of at least 0.1 mg/L at all times at any point in the water distribution system
Total Trihalomethanes (THMs)	Less than or equal to 0.10 mg/L as locational annual average of quarterly samples
Total Haloacetic Acids (HAAs)	Less than or equal to 0.08 mg/L as locational annual average of quarterly samples
Lead	Less than or equal to 0.01 mg/L in the water distribution system

Water samples are retrieved, tested, and recorded onsite for chlorine levels each day. There are two chlorine standards, one for leaving the reservoir and one for within the distribution system. The minimum free chlorine standards are 0.5 mg/L leaving the reservoir and 0.1mg/L throughout the distribution system.

These charts outline the 2021 Chlorination results leaving the Schanzenfeld and Reinfeld reservoirs as reported by the Utility Operator.

**2021 Schanzenfeld**

Month	# of Samples	
	Taken	Compliance
January	30	100%
February	28	100%
March	31	100%
April	30	100%
May	31	100%
June	30	100%
July	31	100%
August	31	100%
September	30	100%
October	31	100%
November	30	100%
December	31	100%

**2021 Reinfeld**

Month	# of Samples	
	Taken	Compliance
January	31	100%
February	28	100%
March	31	100%
April	30	100%
May	31	100%
June	30	100%
July	31	100%
August	31	100%
September	30	100%
October	31	100%
November	30	100%
December	31	100%

The following outlines the 2021 test results as submitted by the Operator to ALS Environmental for analysis. Samples are submitted every two weeks from the incoming treated water (PVWC), the outgoing treated water from the reservoir, and a distribution system location. The distribution chlorine residuals are measured at the same time and location as the bacteriological distribution samples and are included in the chart below.

**Blumstein**

This system runs off PVWC's line between Winkler and Morden. The chlorine residual is dependent on PVWC chlorination.

**Coliforms & E. coli - Outflow Treated**

Date	In Distribution System					
	Coliforms MPN/100ml	E. coli MPN/100ml	Compliant	Chlorine Free mg/L	Chlorine Total mg/L	Compliant
Jan 7/21	0	0	Yes	0.91	1.11	Yes
Jan 20/21	0	0	Yes	0.56	0.91	Yes
Feb 4/21	0	0	Yes	0.65	1.19	Yes
Feb 18/21	0	0	Yes	0.59	0.73	Yes
Mar 3/21	0	0	Yes	0.38	0.73	Yes
Mar 17/21	0	0	Yes	0.57	0.93	Yes
Mar 31/21	0	0	Yes	0.46	0.69	Yes
Apr 14/21	0	0	Yes	0.56	0.81	Yes
Apr 28/21	0	0	Yes	0.74	0.94	Yes
May 13/21	0	0	Yes	0.61	0.83	Yes
May 25/21	0	0	Yes	0.63	0.86	Yes
June 7/21	0	0	Yes	0.30	0.95	Yes
June 21/21	0	0	Yes	0.77	1.12	Yes
July 8/21	0	0	Yes	0.39	0.61	Yes
July 19/21	0	0	Yes	0.86	0.92	Yes
Aug 3/21	0	0	Yes	0.33	0.70	Yes
Aug 16/21	0	0	Yes	0.32	0.61	Yes
Sept 1/21	0	0	Yes	0.28	0.62	Yes
Sept 13/21	0	0	Yes	0.63	0.99	Yes
Sept 27/21	0	0	Yes	0.67	0.91	Yes
Oct 12/21	0	0	Yes	0.36	0.60	Yes
Oct 25/21	0	0	Yes	0.41	0.72	Yes
Nov 8/21	0	0	Yes	0.77	1.13	Yes
Nov 22/21	0	0	Yes	0.61	0.82	Yes
Dec 6/21	0	0	Yes	0.61	0.86	Yes
Dec 20/21	0	0	Yes	0.17	0.33	Yes



## Reinfeld Distribution

### Coliforms & E. coli – Distribution system

Date	In Distribution System					
	Coliforms MPN/100 ml	E. coli MPN/100ml	Compliant	Chlorine Free mg/L	Chlorine Total mg/L	Compliant
Jan 7/21	0	0	Yes	1.00	1.36	Yes
Jan 20/21	0	0	Yes	1.03	1.31	Yes
Feb 4/21	0	0	Yes	1.03	1.53	Yes
Feb 18/21	0	0	Yes	0.99	1.11	Yes
Mar 4/21	0	0	Yes	0.96	1.59	Yes
Mar 17/21	0	0	Yes	0.86	1.10	Yes
Mar 31/21	0	0	Yes	1.08	1.36	Yes
Apr 14/21	0	0	Yes	0.85	1.21	Yes
Apr 28/21	0	0	Yes	1.21	1.35	Yes
May 13/21	0	0	Yes	0.99	1.38	Yes
May 25/21	0	0	Yes	0.81	1.12	Yes
June 7/21	0	0	Yes	0.43	0.86	Yes
June 21/21	0	0	Yes	0.91	1.01	Yes
July 8/21	0	0	Yes	0.87	1.09	Yes
July 19/21	0	0	Yes	0.64	1.03	Yes
Aug 3/21	0	0	Yes	0.95	1.37	Yes
Aug 16/21	0	0	Yes	1.09	1.39	Yes
Sept 1/21	0	0	Yes	0.62	0.81	Yes
Sept 13/21	0	0	Yes	0.98	1.38	Yes
Sept 27/21	0	0	Yes	0.76	1.25	Yes
Oct 12/21	0	0	Yes	0.98	1.16	Yes
Oct 25/21	0	0	Yes	1.29	1.76	Yes
Nov 8/21	0	0	Yes	0.97	1.32	Yes
Nov 22/21	0	0	Yes	1.37	1.70	Yes
Dec 6/21	0	0	Yes	0.73	1.16	Yes
Dec 20/21	0	0	Yes	1.22	1.67	Yes

**Schanzenfeld Distribution**

**Coliforms & E. coli - Outflow Treated**

Date	In Distribution System					
	Coliforms MPN/100ml	E. coli MPN/100ml	Compliant	Chlorine Free mg/L	Chlorine Total mg/L	Compliant
Jan 7/21	0	0	Yes	0.96	1.28	Yes
Jan 20/21	0	0	Yes	0.72	1.14	Yes
Feb 4/21	0	0	Yes	0.96	1.50	Yes
Feb 18/21	0	0	Yes	0.91	0.99	Yes
Mar 4/21	0	0	Yes	0.81	1.10	Yes
Mar 17/21	0	0	Yes	0.45	0.78	Yes
Mar 31/21	0	0	Yes	1.07	1.31	Yes
Apr 14/21	0	0	Yes	0.61	0.95	Yes
Apr 28/21	0	0	Yes	1.01	1.46	Yes
May 13/21	0	0	Yes	0.86	0.98	Yes
May 25/21	0	0	Yes	1.11	1.36	Yes
June 7/21	0	0	Yes	0.91	0.99	Yes
June 21/21	0	0	Yes	0.76	1.12	Yes
July 8/21	0	0	Yes	0.78	1.05	Yes
July 19/21	0	0	Yes	0.87	1.16	Yes
Aug 3/21	0	0	Yes	0.81	0.99	Yes
Aug 16/21	0	0	Yes	0.82	1.21	Yes
Sept 1/21	0	0	Yes	0.91	1.11	Yes
Sept 13/21	0	0	Yes	0.96	1.27	Yes
Sept 27/21	0	0	Yes	0.76	1.18	Yes
Oct 12/21	0	0	Yes	1.01	1.18	Yes
Oct 25/21	0	0	Yes	1.21	1.36	Yes
Nov 8/21	0	0	Yes	0.67	0.98	Yes
Nov 22/21	0	0	Yes	1.32	1.60	Yes
Dec 6/21	0	0	Yes	0.81	0.96	Yes
Dec 20/21	0	0	Yes	0.98	1.61	Yes

At any time when the free chlorine residual requirement is not met immediate action is taken by the Operator to adjust amounts of chlorine being added to ensure future compliance.

## **THM's & HAA's**

Every two years, quarterly testing is done for THM's & HAA's as required by the Office of Drinking Water. Reporting years are 2022, 2024 and so on. There was no testing done in 2021. These were the results from **2020**. 2022 results will be on the 2023 annual report.

***Trihalomethanes (THM's)*** are formed when chlorine reacts with naturally occurring organic matter in the water. Studies have shown a link between high levels of THM's and cancer. For that reason, the province has set a health-based standard for THM's of *0.1mg/L*. THM's were tested in the Schanzenfeld Public Water System in 2020 producing the following results. Compliance with provincial standards is dependent on the effectiveness of the treatment process.

### ***THM's***

Feb. 2020	0.135 mg/L
May 2020	0.104 mg/L
Aug. 2020	0.253 mg/L
Nov. 2020	0.189 mg/L

***Haloacetic acids (HAAs)*** are a common undesirable by-product of drinking water chlorination. HAAs can be formed by chlorination, ozonation or chloramination of water with formation promoted by slightly acidic water, high organic matter content and elevated temperature. Chlorine from the water disinfection process can react with organic matter and small amounts of bromide present in water to produce various HAAs. The MAC (maximum acceptable concentration) for HAA's is 80 ug/L (micrograms/liter). Compliance with provincial standards is dependent on the effectiveness of the treatment process. Testing was done in Reinfeld producing the following results.

### ***HAA's***

Feb. 2020	62.2 ug/L
May 2020	48.3 ug/L
Aug. 2020	72.5 ug/L
Nov. 2020	69.4 ug/L

### **Water system incidents.**

5 water breaks were recorded for 2021. They were all repaired without incident.

### **Drinking water safety orders on system.**

None

### **Boil water advisories issued.**

Due to some system maintenance, 1 maintenance boil water advisory was issued in 2021 for a small portion of Blumstein. Sampling and testing came back negative.

Another BWA was issued for a small area north of Winkler. Due to line upgrades, a number of homes were on boil water for a bit.

**Warnings issued or charges laid in accordance with Drinking Water Safety Act.**

None.

**Annual Audit by the Office of Drinking Water**

A copy of the annual audit done by the Office of Drinking water is available by request through the RM of Stanley.

**Permits and Licenses**

All operator licenses are valid and up to date. A third part time fully licensed operator has been added as a contract employee. System permits are also all in place as required. This information is posted at every site and available at the RM of Stanley Office.

**Major Expenses Incurred.**

None

**Anticipated Expenses**

A reservoir cleaning at the Schanzenfeld reservoir is planned. The estimated cost of this is \$10,000.

**Future system expansion.**

A 4 million litre reservoir build in the Winkler/Morden Corridor is in the planning stages and awaiting funding approvals. With the likelihood of low-pressure sewer coming into the Villages of Reinfeld and Schanzenfeld, we can expect those systems to double in the next 20 years from the new growth.

The possibility of the system being partially or fully fed from PVWC Morris plant is also the basis of an on-going project between the PVWC and MWSB.

**RM of Stanley Notifications**

**[Stay Connected! Register Today!](#)**

We are pleased to announce the launch of Connect Stanley, our new communication system. Along with a new website and mobile apps, we will keep you alerted on road closures, other public works and transportation notices, burning restrictions, water service disruptions and emergency alert messages from Canada's national emergency alerting system (Alert Ready). You decide how you want to receive information, whether it be by text messages, phone calls, e-mails or any combination you choose.

Register with us never miss out on the latest news on road closures, other public works and transportation notices, burning restrictions, water service disruptions and emergency alert messages from Canada's national emergency alerting system (Alert Ready).

A free copy of the 2021 Annual Report can be obtained at the RM office.